

R-10 Rifle Instructions

IMPORTANT: Please read these instructions and view the CD-ROM before first using your rifle.



www.bsaguns.co.uk



NUMBER OF SHOTS (Approx)

	Carbine	Fill Pressure
.177 12 ft lbs	150 shots	232 bar
.22 12 ft lbs	180 shots	232 bar
.177 FAC 21 ft lbs	60 shots	232 bar
.22 FAC 31 ft lbs	50 shots	232 bar

Gun Safety

- Make sure you know the laws relating to airguns, and abide by them.
- When you pick up any gun always check that it is not loaded.
- Never point a gun at anyone or anything that is not a legitimate target.
- Never leave your rifle unattended, even if it's unloaded.
- Gun safety is a state of mind; never rely on a safety catch.
- After use, put your rifle away safely; unloaded and out of reach of children. Store your pellets separately.
- Always ensure it is safe to shoot and be certain of your target before you squeeze the trigger.
- Make sure there is a safe backstop behind your target to catch your pellet in case you miss.
- Beware of ricochets – do not shoot at water or other smooth surfaces that may deflect the pellet in a different direction.
- Always unload your gun when crossing obstacles, taking it indoors or into a car.
- When carrying your rifle, be sure the muzzle is always pointing in a safe direction in case you should stumble.
- Never shoot on land without written permission from the owner.

Safety Warning

- Use only dry breathing air.
- In the interest of safety any physical damage to air cylinders or filling tanks (e.g. dents, rust etc), and their fittings and valves must require the return of the item(s) to the manufacturer or their appointed agent for inspection.
- Any modification or service to the product must only be carried out by the manufacturer or their appointed agent. On no account should owners attempt to work on or modify guns.
- Do not exceed the manufacturers maximum fill pressure for the gun.
- Because of the high pressures involved the air reservoir should be checked periodically by the factory or an appointed agent of the company. BSA recommend a visual inspected every 3 years and pressure tested every 10 years.
- When storing your gun avoid excessive heat, cold or humidity.

Technical Information

All BSA airguns are made to the highest standards at our factory in Birmingham. BSA barrels are cold hammer forged and crowned for optimum accuracy.

Before leaving the factory every airgun is tested on special purpose machinery to verify velocity and pellet grouping. UK law dictates that air rifles should not be capable of above 12 ft-lb muzzle energy; all BSA models conform to this requirement. Export models are supplied to conform to the laws in the destination country.

Using Compressed Air

CAUTION!

Only dry breathing quality air should be used in guns. Never fill any gun with oxygen, or any other gas. Doing so could cause a serious explosion.

High pressure compressed air can be used safely provided proper procedures are followed, if you are not sure of the procedure ask your gun shop for advice.

Never try to fit a buddy bottle to the gun when the rifle is in a partially assembled state.

The removable 'buddy' bottle can be filled from an air tank or using a hand pump. Whichever equipment is used, a pressure gauge and supply hose bleed device must be included, and the manufacturer's instructions must always be followed.

Filling the R-10

The maximum filling pressure for the R-10 is 232 bar, do not over charge the rifle as this may be dangerous. Doing so will reduce the power and damage the rifle.

When filling the gun via the quick fill use the gauge on the scuba tank to read the pressure.

The buddy bottle can be removed and changed for a spare bottle in the field if required. The buddy bottle can be filled with air in two ways;

1. Via the quick-fill port situated in front of the pressure gauge using the filling probe supplied with the gun.
2. By removing the bottle from the gun and refilling it using a bottle filling adaptor (part number 16-6440, not supplied) and replacing the bottle on the gun.

Using the Quick-Fill

A filling adaptor is supplied with each rifle; this has a restrictor screw fitted in its base, which must be screwed down tightly when using an air tank to fill the gun, or the rifle could be damaged. If using a hand pump the restrictor screw should be loosened or removed using the Allen key provided.

- Before filling always make sure the gun is not loaded.
- If the buddy bottle is empty, cock the rifle before filling.
- Insert the filling adaptor into the filling port and push it home.
- Make sure the bleed screw on the charging unit is closed, and then start the charging process by opening the air bottle valve slowly.
- Allow the air to slowly fill the gun to 232 bar and close the valve. Allow a few minutes for the pressure to settle, and then, if necessary top up the pressure using the same procedure.
- Quickly open the bleed valve on the charging unit to allow the air in the hose to escape.
- Pull the filling adaptor from the filling port.
- Once the filling operation is completed, de-cock the rifle. Pull back the bolt and while holding the bolt back pull the trigger and slowly allow the bolt to move forward until it has returned to the rest position.

Regularly check the condition of the filling probe "O" rings and apply a little Molycote 111 grease. Only use this grease on the "O" rings as automotive mineral oils and grease can cause an explosion if used with high-pressure air.

Removing the Buddy Bottle

Unless you need to remove the buddy bottle it is recommended that the rifle is filled using the filling probe.

- Apply the safety catch, remove the magazine and check that there is not a pellet in the barrel, if in doubt point the rifle in a safe direction and fire the rifle to ensure that the barrel is clear.
- To avoid damage to the buddy bottle "O" ring, which can result in leaks, it is essential to first close the valve in the buddy bottle by unscrewing it one full turn. There will still be some compressed air in the rifle's regulator. To release this, point the gun in a safe direction, take off the safety catch and fire the gun several times. Repeat the firing-cycle until the muzzle discharge becomes quieter and the pressure gauge reads empty.
- If the muzzle report is still loud after firing the gun 8-10 shots and the gauge is still showing air in the gun, unscrew the bottle a further quarter turn and repeat the process. Once the rifle is empty the bottle can easily be un-screwed.

Filling the Bottle with Air

A filling adaptor which screws onto the top of the buddy bottle (part number 16-6440, not supplied) is obtainable from BSA stockists.

- Check that the threads on the bottle and filling adaptor are clean, and then screw the bottle into the adaptor until it is tight.
- The procedure for refilling the bottle is identical to that when using the filling probe.

Telescopic Sights

The BSA R-10 has a full length integral 10.8mm dovetailed scope rail designed to accept standard scope mounts and night vision equipment. Refer to the scope manufacturer's instructions on fitting and adjusting.

Butt Plate

The butt plate can be adjusted for elevation to suit your individual preference. Loosen the central locking screw and find the position that best matches your ideal sighting and comfort. Tighten the screw to lock the plate.

Loading the Gun

- Apply the safety catch and remove the magazine from the gun by pushing the magazine retaining catch forward.
- Lift the bolt handle and pull back as far as it will go, and while holding the bolt right back, remove the magazine.
- Hold the magazine between finger and thumb with the cover plate screw uppermost. Push a pellet nose first into the first magazine chamber and press down until the pellet skirt is under the cover plate (see Fig 1).
- Rotate the central body of the magazine anti-clockwise until the next vacant position lines up with the hole in the cover plate. Insert another pellet and repeat the procedure until the magazine is full (see Fig 2).
- The red dot on the magazine body will be at the top when all ten pellets are loaded.
- At any stage during loading, the magazine body can be moved back one position by pressing the escapement mechanism lever (see Fig 3).
- Replace the magazine in the rifle (see Fig 4), slide the bolt forward and down into the retaining slot and take off the safety catch. The rifle is now ready to fire.
- When the tenth and final pellet has been indexed into position, a red spot indicator on the magazine body will come into view when the bolt is pulled backwards to cock the rifle. Lock down the bolt in the forward position to fire the last shot.

Note: The magazine is factory filled with lubricating grease. Take care to avoid contamination with dirt or grit and always carry magazines in a sealed plastic bag. Do not take the magazines to pieces, or remove this grease.



The Shrouded Barrel Assembly

The BSA R-10 incorporates a shrouded barrel fitted with a ported muzzle break. The shroud is mounted over 2 spacing collars to maintain alignment with the barrel. All U.K specification rifles incorporate a sound suppression system within the shroud assembly. Access to the suppressor components is achieved by unscrewing the shroud from its connector, located next to the breech block.

If an additional silencer is desired, unscrew and remove the muzzle break from the shroud adaptor. This will reveal the 1/2" UNF thread most commonly used on after-market silencers.

Care and Maintenance

After use, check that your rifle is unloaded and wipe the metal and woodwork surfaces with a lightly oiled cloth. Pay special attention to the metal finishes as these are not fully rustproof and are vulnerable to damp and particularly perspiration. If your rifle has become damp, make sure it is completely dry before you put it away.

The R-10 has a grade 2 walnut stock with an oil finish. Periodic application of a **small** amount of a proprietary stock finishing oil is all that is required. Alternatively linseed or walnut oil could be used.

Never use oils containing silicone as they can cause damage to metal surfaces. Application of oil and grease except as directed by the manufacturer can often do more harm than good.

Your rifle has been designed and manufactured for optimum performance. Tampering with the components, or unauthorised modifications and alterations may make the rifle unsafe to use and will invalidate the

Trigger Adjustments

The trigger is set at the factory, but some aspects can be adjusted to suit individual preferences.

Before adjusting the trigger, remove the magazine and check that there is not a pellet in the barrel, if in doubt point the rifle in a safe direction and fire the rifle to ensure that the barrel is clear.

Remove the Buddy Bottle as described previously, then remove the stock assembly.

In the interests of safety, take care not to over-lighten the trigger weight.

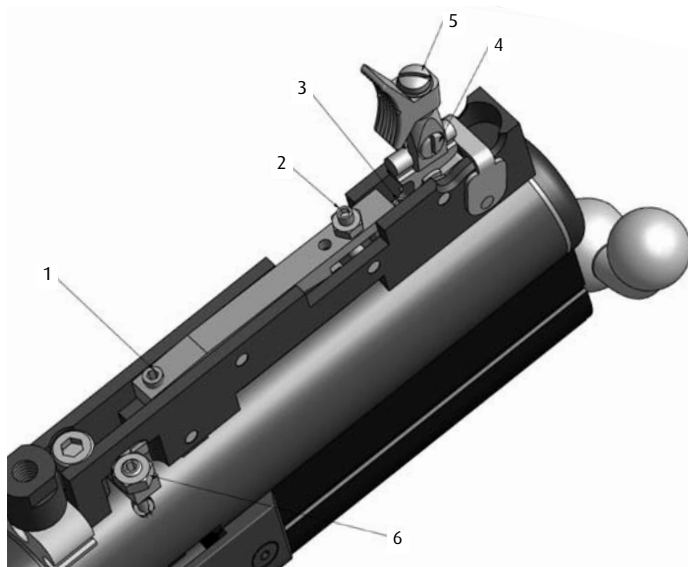

1. Trigger pull.

This screw adjusts the weight of second stage trigger pull, to increase the weight of pull turn the screw clockwise and anti-clockwise to reduce the weight of pull.

2. Sear engagement screw.

This screw determines the length of the second stage release. Should you wish to adjust the length of the second stage release, slacken off the locknut and adjust the screw the desired amount. Turning the screw clockwise reduces the second stage release; turning it anti-clockwise increases the second stage release.

CAUTION GREAT CARE SHOULD BE TAKEN IN THE ADJUSTMENT OF THIS SCREW. ANY EXCESSIVE CLOCKWISE TURN COULD RENDER THE GUN IN A CONDITION IN WHICH IT COULD FIRE ACCIDENTALLY. IF IN ANY DOUBT CONSULT A QUALIFIED GUNSMITH

3. First stage trigger adjustment.

This is factory preset and must not be adjusted.

4. The trigger grip can be adjusted lengthways, sideways and swivelling using screws 4 and 5. It is not necessary to remove the stock to carry out these adjustments.

Magazine Indexing Mechanism

The magazine indexing mechanism is factory set to operate automatically during the cocking and firing cycles of the rifle. The mechanism should not be adjusted unless the magazine fails to index.

To test the indexing, rotate the magazines' rotor **WITHOUT LOADING ITS CHAMBERS WITH PELLETS** and refit the magazine to the rifle. Point the rifle towards a safe target and fire. Re-cock the rifle and observe whether the rotor indexes to the next chamber.

If the rotor has not cycled, undo the magazine actuator screw locknut (6) and turn the actuator screw approx. 1/2 turn clockwise when viewed beneath. Retighten the locknut and retest the indexing mechanism. Repeat the procedure if necessary until the correct indexing is achieved.

Note: If the actuator screw is reset, the magazine actuator must retain a small amount of rotational movement after the rifle has been fired. Failure to maintain this movement will restrict or prevent hammer movement which will impair the rifles' performance.

warranty. All air rifles require periodic maintenance and inspection, so even if everything seems to be in good working order, have your air rifle checked periodically by a competent gunsmith. You should always have the power of your air rifle re-checked following any maintenance or repair work as any repairs or adjustments could affect the power. **It is your legal responsibility to make sure the air rifle remains below the legal power limit, which in the UK is 12 ft-lb.**

Diagrams and parts lists are available on our website at www.bsaguns.co.uk

2 Year Warranty All new BSA rifles carry a 2 year warranty against faulty parts and labour, this applies to new rifles only and is not transferable; proof of purchase is required. Excluded from this warranty are: failure due to misuse or abuse, the fitting of non-standard parts, and fair wear and tear including damage to the stock. All warranty work must be done by BSA or an authorised agent of the company, and should the rifle be collected or returned under warranty, BSA or their authorised agent reserve the right to charge for postage and / or inspection.